

# Exhibitors:

Be part of Europe's leading event for the Premium Seat & Hospitality sector

# ALSD INTERNATIONAL

September 6 - 7, 2021 • Liverpool FC's Anfield Stadium • Liverpool, UK



Liverpool FC's  
Anfield Stadium

Presented by:



< POWERED BY **ungerboeck** >

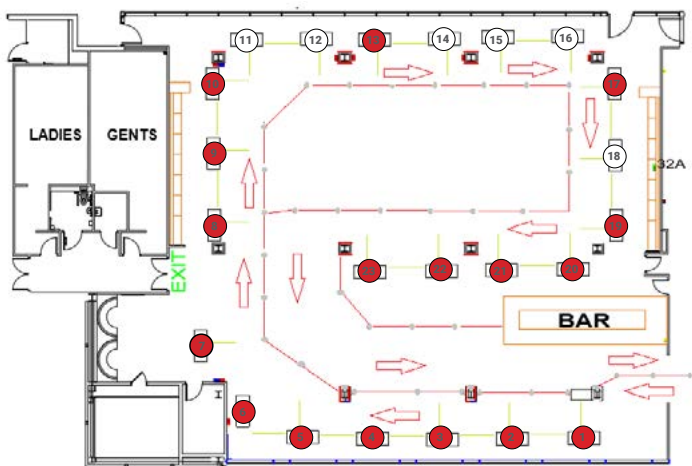

Exhibition Hall: The Beautiful Game, Anfield Stadium

● = Unavailable

**ALSD International** - Europe's one and only conference and exhibition dedicated to the Premium Seat & Hospitality sector - is coming to the iconic home of **Liverpool Football Club, Anfield Stadium**, in the beautiful city of Liverpool, September 6 - 7, 2021.

The event will be fully virtualised, with all conference sessions to be streamed, the exhibition and networking to be digitalised, plus there will be Organisers TV, running videos, presentations, interviews and more.

With sports projects aplenty and a variety of world-class sports venues, Liverpool offers the perfect platform to examine premium seating and how to increase revenue with new builds, renovations and service expansions, as well as via new F&B offerings and the latest innovations in technology.

Attendees will benefit from a comprehensive conference program delivered by the sector's leading experts, as well as unrivalled networking opportunities, behind-the-scenes tours of not only Anfield but also **Everton Football Club's Goodison Park** and **M&S Bank Arena Liverpool** and an exhibition showcasing the latest innovations, technologies and solutions.

For more information: [www.ALSDIInternational.com](http://www.ALSDIInternational.com)

**All exhibiting companies receive:**

- 3 complimentary physical passes and 3 complimentary virtual passes. (Additional passes available.)
- 100-word company profile in the Conference Program and on the ALSDI website
- Regular inclusion of press releases, news stories, case studies, etc., across the ALSD International and Sports Venue Business platforms.

**Exhibit Only  
(Virtual & Physical - Hybrid Event)**

- 3m x 2m exhibit space (with table and 2x chairs), plus virtual exhibition space and networking lounge.  
€2,500 / £2,120 / \$2,800 + VAT

**Exhibit Only  
(Virtual Only - Hybrid Event)**

- Virtual exhibit space, including networking lounge.  
€1,250 / £1,130 / \$1,480 + VAT

**PAYMENT**

All booth applications must be accompanied by full payment for exhibit space requested on the Exhibitor Prospectus. In addition, 25% of the exhibitor application fee is a non-refundable deposit (see cancellation policy for additional information).

**CANCELLATION OF EXHIBIT SPACE**

All cancellations must be in writing to the exhibition coordinator: Katie McIntyre. Written notification received by August 1, 2021, will result in a 75% refund; payable 30 days after the conference and tradeshow. After August 1, 2021, no refund will be returned.

**FAILURE TO OCCUPY EXHIBIT SPACE**

Booth exhibitor space not occupied by the close of exhibit set-up time will be forfeited by the exhibitor. If the exhibitor is on hand, show management may assign labour to set up any display that is not in the process of being set up by the given deadline. The exhibitor is responsible for all costs and expenses incurred.

**INSTALLATION AND DISMANTLING OF EXHIBITS**

Exhibitor agrees to provide all labour, materials and tools required for the installation and dismantling of exhibits. Shipping, installation, storage and dismantling of exhibits are paid for by the exhibitor to show decorator. The exhibitor will perform this action during the allotted times of exhibitor set up and dismantling. Exhibitor also agrees to arrange for the removal of its freight from the exhibit hall at the conclusion of the conference and exhibition. Removal of freight must be in accordance with local union guidelines. Failure to remove exhibit material will result in the exhibitor being charged for cost and expense of any clean-up or removal.

**EXHIBITION FLOOR PLAN**

Exhibit floor space is limited and allotment is determined on a first-come, first-served basis. Premium booth locations will be based on the number of factors including number of years exhibiting at ALSD, size of booth and relative time of space commitment.

**EXHIBITORS:**

Email Jared Frank (jared@alsd.com) a brief company description (100 words or less) of your company's product or service. This will be published in the 2021 ALSD International Conference Program. Deadline August 1, 2021. Additionally, please send a copy of your official company logo via email to Amanda@alsd.com.

**Host Hotel:**

Pullman Liverpool, Monarch Quay  
Kings Dock, Liverpool L3 4FP - UK

**Special Delegate Rates**

£110 per night B&B (single)  
£125 per night B&B (double)

Payment terms: Guests to settle own account

**Exhibiting Company Sign-Up:**

Exhibition Coordinator (please check):

Exhibition Coordinator will attend  
ALSD International Conference

Company \_\_\_\_\_

Address \_\_\_\_\_

City/State \_\_\_\_\_

Postal Code/Zip \_\_\_\_\_

Phone \_\_\_\_\_

Fax \_\_\_\_\_

Email \_\_\_\_\_

\_\_\_\_\_  
Authorised Signature

Exhibition Coordinator should receive:

(please check):

Drayage / Shipping information

If no, please state appropriate (or additional) contact: \_\_\_\_\_

ALSD International Conference  
Announcements

If no, please state appropriate (or additional) contact: \_\_\_\_\_

Please ensure to tick the box to opt-in to receive all important event information.

**Three (3) Complimentary Attendees:**

\*Attendees MUST be submitted no later than August 1, 2021. Include contact person above if that person is attending.

Name \_\_\_\_\_

Title \_\_\_\_\_

Email \_\_\_\_\_

Phone \_\_\_\_\_

Name \_\_\_\_\_

Title \_\_\_\_\_

Email \_\_\_\_\_

Phone \_\_\_\_\_

Name \_\_\_\_\_

Title \_\_\_\_\_

Email \_\_\_\_\_

Phone \_\_\_\_\_

**Additional Attendees:**

€280 / £245 / \$350 + VAT Per Additional Attendee. Inquire with ALSD International.

Please ensure to tick the box to opt-in to receive all important event information and consent to ALSD International holding your data, as per GDPR regulations.

**ALSD Guest/Spouse Program:**

If you bring a guest(s), that person(s) will need credentials. Extra credentials are €165 / £140 / \$180 + VAT each and will grant guests access to receptions/tours. Inquire with ALSD International.

**PAYMENT**

Exhibit Space/Package (see details at left) = £/\$ \_\_\_\_\_

Additional Attendees £245/\_\_\_\_\_ attendees = £/\$ \_\_\_\_\_

Guest(s) £245/\_\_\_\_\_ guests = £/\$ \_\_\_\_\_

Grand Total £/\$ \_\_\_\_\_

Plus VAT @20% £/\$ \_\_\_\_\_

(NB: If you're VAT registered and based in Europe, please provide your VAT number.)

**Credit Card**

American Express  MasterCard  Visa

Card No. \_\_\_\_\_ Exp. : \_\_\_\_\_

Cardholder Name (printed) \_\_\_\_\_

Cardholder Signature \_\_\_\_\_

**Cheques** made payable to: Association of Luxury Suite Directors, Association of Luxury Suite Directors, 10017 McKelvey Road, Cincinnati, OH 45231 USA. T: +1 513 674 0555

Please complete and email Exhibitor Only Application to:

ATTN:

Katie McIntyre

katie@alsd.com

T: +353 (0)44 9335212